

Database search Orchestrator for cloud database

Shweta Agrawal *1, Raj Kamal #

*School of Computer Science and IT, DAVV, Indore, 452001, India

#Medicaps Institute of Technology and Science, Indore, 453331, India

Abstract: Cloud computing is an emerging paradigm in the field of distributed computing. Orchestrator is a manager which coordinates the distributed tasks. An Orchestrator, Computational Orchestrator (CompOrch) [1] is presented in our previous work. CompOrch is a super class for the various distributed tasks. It includes the Orchestration of mathematical applications, distributed robotic tasks and networked control systems. The paper proposes the extension of CompOrch for searching data in cloud database environment.

I. INTRODUCTION

Cloud computing is a new computing paradigm. Cloud computing aims to provide reliable, customized and Quality of Service (QoS) guaranteed computing environments for end-users. Cloud computing enables users to move their data and computation to a remote location. It also ensures the quality in system performance [2].

The basic principle of cloud computing is that user data is not stored locally but is stored in the data center of Internet [3]. The users can access the stored data at any time by using Application Programming Interface (API) provided by cloud providers. The provider also provides hardware and software services for the general public and business markets. The services provided by service providers can be everything, from the infrastructure, platform or software resources. These services are respectively called Infrastructure as a Service (IaaS), Platform as a Service (PaaS) or Software as a Service (SaaS) [4].

Automation in cloud computing requires everywhere. Orchestrator [5] [6] is a tool used to automate the distributed services. Numerous Orchestrators are available to orchestrate the computation in clouds. The paper describes the study of various cloud Orchestrators. It also describes use of Orchestrator in searching data.

II. NEED OF ORCHESTRATOR IN CLOUD COMPUTING

Orchestration provides composition and coordinated execution of services. It allows centralized management of web services. The goal of cloud orchestration is to; automate the configuration, coordination, management and orchestrate workflow software. Management of physical and virtual resources, namely servers, storage, and networks, is a challenging job for cloud providers. The orchestration enables rapid and dynamic provisioning of resources to the users and applications. The Orchestrator is basically required for the following functionalities:

- Management of synchronous flows with, complex interaction patterns, for example, parallel invocations, serial invocations and time bound executions.
- Management of asynchronous flows where processes may need to wait for some events to fire.
- Managing fault tolerance.
- Interaction with user.
- Providing flexibility for various choices that include: type of services for integration, mode of execution.

The diversified requirements in cloud need an organized and well-structured middleware system.

III. ORCHESTRATORS IN CLOUD COMPUTING ENVIRONMENT

A cloud Orchestrator is a software that manages the interconnections and interactions among cloud-based and on-premises business units. Cloud Orchestrator products use workflows to connect various automated processes and associated resources. Table 1 gives models of cloud Orchestrators and their descriptions.

TABLE 1 CLOUD ORCHESTRATORS

S.No.	Models Presented	Features
1	Decentralized orchestration of data centric workflows[7]	<ul style="list-style-type: none"> • A flexible and lightweight workflow framework based on the Object Modelling System (OMS). • Executes data-centric workflows in a decentralized manner across multiple distinct Cloud resources, avoids limitations of all data passing through a centralized engine.
2	LiveCloud: An Orchestrator for cloud data centers[8]	<ul style="list-style-type: none"> • A Management framework for resource management in cloud data centers. • Management is done for resource allocation and resource coordination.
3	An Orchestrator for resource management in cloud[9]	<ul style="list-style-type: none"> • It works on the basis of ODA (observe, decide and act) loops. • It observes the running applications through the monitoring APIs. • The monitored information is send to the service, which is responsible for the decision • Each service controls a set of actuators to perform a given task.

S.No.	Models Presented	Features
4	IBM smart cloud Orchestrator[10]	<ul style="list-style-type: none"> • IBM cloud Orchestrator provides cloud management for IT services, allowing accelerating the delivery of software and infrastructure. • Based on open standards, it reduces the number of steps to manage public, private and hybrid clouds by using an easy-to-use interface.
5	Eucalyptus FastStart: Easy Private Cloud Setup With Advanced Cloud orchestration Tools[11]	<p>Figure 1 shows the architecture of Eucalyptus Orchestrator. It consists following components</p> <ul style="list-style-type: none"> • Cloud Controller (CLC), providing compute functionality. • Walrus Storage, providing object storage functionality. • Cluster Controller (CC), providing management service for a cluster. • Storage Controller (SC), providing EBS or persistent block storage. • Node Controller (NC), providing controls for virtual machine instances.
6	Flexiant cloud Orchestrator[12]	<p>Figure 2 shows the flexiant cloud Orchestrator. It provides following features:</p> <ul style="list-style-type: none"> • Flexible Self-Service • Powerful User Interface • Multi-Cluster Scalability • Application Blueprints • Extensibility
7	TROPIC: Transactional Resource orchestration Platform In the Cloud[13]	<ul style="list-style-type: none"> • TROPIC's orchestration procedures are transactional, automatically guaranteeing atomicity, consistency, isolation and durability of cloud operations. • TROPIC can meet production-scale cloud orchestration demands, while maintaining design goals of safety, robustness, concurrency and high availability.

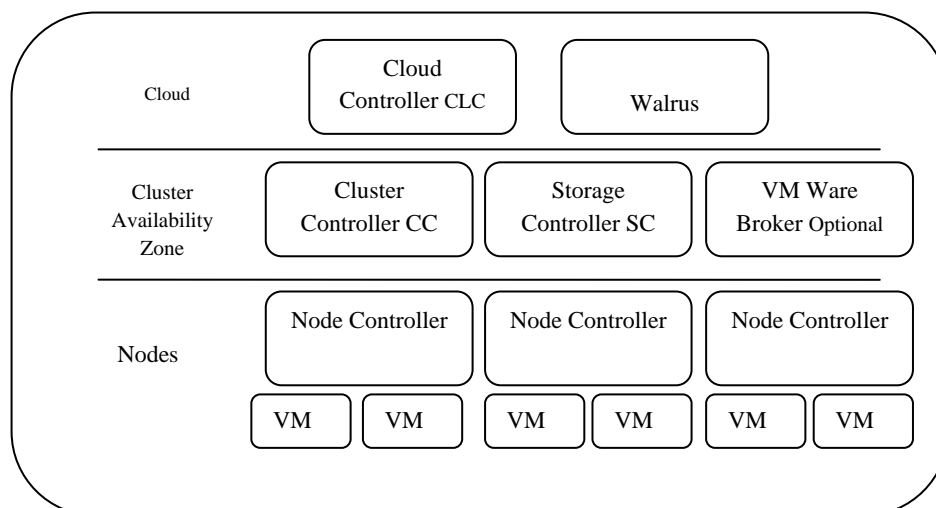

Fig.1: Eucalyptus architecture components [11]

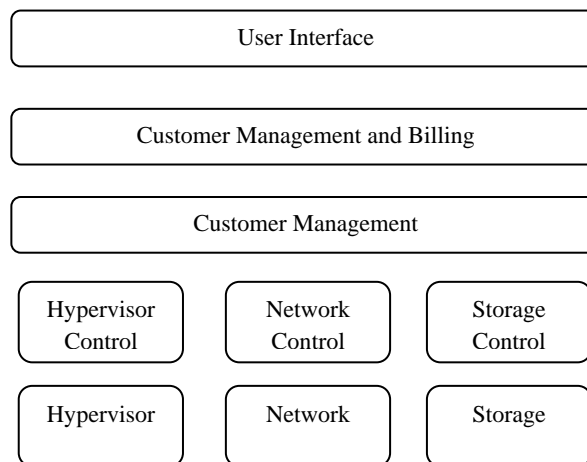

Fig.2: Flexiant cloud Orchestrator [12]

IV. DATA STORAGE IN CLOUDS

The data storage that resides in the cloud is called as cloud based database. Several Providers offer cloud based database. The techniques for accessing data through cloud database are as follows [14]: Through a web browser interface that allows moving files to and from the storage area, through a mounted disk drive that appears locally on computer as a disk drive, through the set of API calls.

The examples of cloud based database include: Microsoft skydrive, Oracle cloud file system [15], Apache Hadoop [16]: distributed file system, Microsoft SQL azure [17] and Amazon cloud based database.

Advantages of cloud based database solutions include the following [14]: Cloud based database provides scalability and is cost effective also. Cloud based database systems normally reside on multiple servers, which results in high availability, the database providers maintain the database version updates and patches. User is free from the maintenance of data.

Disadvantages of cloud based database include the following [14]: Security is a big issue when storing the data in cloud databases, Data queries travel the Internet, the cloud based database access will not be as fast as the local database.

An Orchestrator can be designed to improve the performance of data search in cloud database. The next section describes the design of such an Orchestrator.

V. AN ORCHESTRATOR FOR SEARCHING DATA IN CLOUD ENVIRONMENT

CompOrch [1] is an Orchestrator, which shows time based execution of services in sequential, parallel and hybrid manner. Extended classes of CompOrch can be used in many applications of cloud computing. The application considered here is searching available data in the cloud database. Data searching can be done in sequential, parallel or in hybrid manner.

Figure 3 shows the Orchestrator for parallel data searching in cloud environment. t_1 is the starting time of the process to data search. Parallel data search allows the Orchestrator to start searching in all servers simultaneously. As soon as Orchestrator gets the data it stops the searching.

$$t_1 = t_2 = \dots t_n \text{ in Figure 3.}$$

Figure 4 shows the sequential data search. Sequential data search follows the following steps: Consider that data may be on any server from n servers. The Orchestrator searches the first server for data, if data is not on the first server it searches the data on to the second server, again if data is not there it goes to the next server. Orchestrator searches to the n^{th} server till the data is not found. As soon as Orchestrator finds the desired data it stops searching.

$$t_1 < t_2 < \dots t_n \text{ in Figure 4.}$$

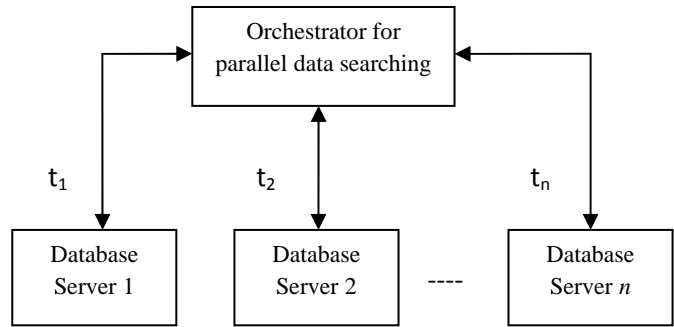

Fig. 3: Parallel Database Search Orchestrator

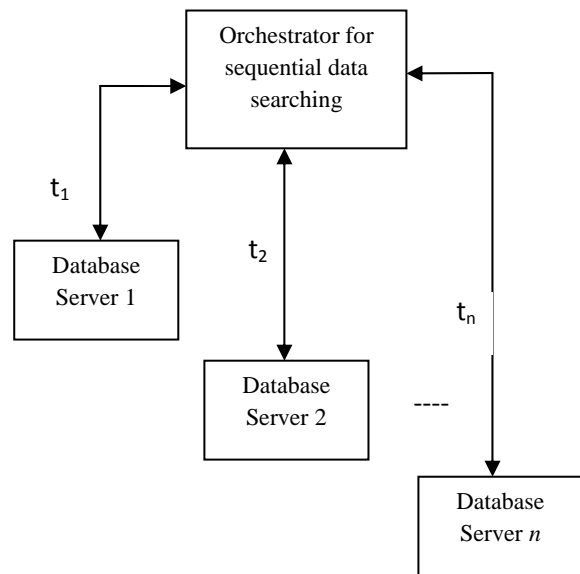

Fig. 4: Sequential Database Search Orchestrator

The user can choose the searching option. The sequential search is time consuming but save the network bandwidth, while parallel data search save time but consumes more network bandwidth.

Another application of CompOrch is Resource management in clouds. Resource management can be done on the time based execution, sequential allocation of resources may be done, parallel allocation or combination of both may be done through CompOrch.

VI. CONCLUSION

There are many Orchestrators for cloud computing. Chapter describes the overview of various Orchestrators designed for cloud computing. Chapter also describes an Orchestrator for database search in cloud computing environment.

REFERENCES

[1] Agrawal S., Raj Kamal , "A design framework of Orchestrator for computing systems," IEEE International Conference on Computer Information Systems and Industrial Management Applications (CISIM), 2010, Gwalior, pp. 410- 413, 8-10 Oct. 2010
 [2] V.Vinothina, R.Sridaran, Dr.PadmavathiGanapathi, "A Survey on Resource Allocation Strategies in Cloud Computing," (IJACSA)

- International Journal of Advanced Computer Science and Applications, pp. 97-104, Vol. 3, No.6, 2012.
- [3] Albert Greenberg, James Hamilton, David A. Maltz, Parveen Patel, "The Cost of a Cloud: Research Problems in Data Center Networks," ACM SIGCOMM Computer Communication Review Vol. 39, No. 1, January 2009
- [4] R. Kalaichelvi Chandrahasan, S Shanmuga Priya , L. Arockiam, "Research Challenges and Security Issues in Cloud Computing," International Journal of Computational Intelligence and Information Security, Vol. 3, No. 3, March 2012
- [5] N. Viswanadham, Kameshwaran, "Orchestrating a Network of Activities in the Value Chain," 5th Annual IEEE Conference on Automation Science and Engineering Bangalore, India, pp. 501-506, August 22-25, 2009.
- [6] BPEL basics for java handlers, available at http://www.activevos.com/indepth/c_technology/bPELForJavaDevelopers
- [7] Bahman Javadi , Martin Tomkob, Richard O. Sinnott c, "Decentralized orchestration of data-centric workflows in Cloud environments," Elsevier journal on Future Generation Computer Systems Vol. 29, No. 7, pp. 1826-1837, 2013
- [8] Xiang Wang, Zhi Liu, Yaxuan Qi, Jun Li, "Livecloud: A Lucid Orchestrator For Cloud Datacenters," IEEE 4th International Conference On Cloud Computing Technology And Science (Cloudcom), pp.341-,348, 3-6 Dec. 2012.
- [9] Gianluca C. Durelli, Marcello Ppogliani, Antonio Miele, Antonios Motakis, Christian Plessl, Heinrich Riebler, Marco D. Santambrogio, Gavin Vaz, Cristiana Bolchini. "Runtime resource management in heterogeneous system architectures: the save approach," the 12th IEEE international symposium on parallel and distributed processing with applications, pp. 142-149, 26-28 Aug. 2014.
- [10] <http://www-3.ibm.com/software/products/en/smartcloud-orchestrator>
- [11] <https://www.eucalyptus.com/cloud-topics/cloud-orchestration-tools>
- [12] <http://www.flexiant.com/flexiant-cloud-orchestrator/>
- [13] Changbin Liu, Yun Mao, Xu Chen, Mary F. Fernández, "TROPIC: Transactional Resource Orchestration Platform in the Cloud, " Usenix atc'12 proceedings of the Usenix conference ,2012.
- [14] Kris Jamsa "Cloud computing" Jones and Bartlett student edition 2014, Jones and Bartlett Learning
- [15] <http://www.oracle.com/us/products/database/cloud-file-system/overview/index.html>
- [16] <http://hadoop.apache.org/>
- [17] <http://azure.microsoft.com/en-us/services/sql-database/>